



WOODWORKS: ADVANCED PROJECT BEDROOM ORGANIZER



Designed as a keeping place for books, school papers and personal items, this Bedroom Organizer is sure to draw praise from all who see it. In fact, don't be surprised if your parents ask you to make another one for them. Inspired by 19th century American furniture, its clean lines make the piece appropriate for any home decor. It is also an excellent project for advanced woodworkers to hone their skills in such techniques as edge joining, ploughing dados and edge rabbets, creating custom moldings, drawer-making, and producing a professional-looking finish.

TOOLS REQUIRED:

- Pencil
- Ruler (zigzag or tape)
- Squares (framing, try and combination)
- 4ft. T-square, or straight edge
- Assorted files, rasps
- Phillips screwdriver (medium)
- Sandpaper (80-grit through 220-grit)
- Hammer and fine nails
- Mallet (wooden or plastic)
- Block plane
- Assorted clamps
- Assorted wood chisels
- Saws (dovetail, band, radial arm)
- Table saw with dado head set
- Jointer
- Sanders (stationary belt and portable belt, random orbit, pad)
- Drill press, or portable electric drill
- Planer
- Cordless drill-driver with Phillips bit
- Router (5/16" and 3/4" dia. straight bits, 1/2" cove bits)
- Safety glasses
- Plate joiner (or dowling jig)

MATERIALS REQUIRED:

See Shopping and Cutting Lists

FINISHING PRODUCTS:

Finish Recommended For This Project

- Minwax® Pre-Stain Wood Conditioner
- Minwax® Wood Finish™ Early American
- Minwax® Wood Finish™ Natural (optional)
- Minwax® Fast-Drying Polyurethane

Alternate Finish Choices

- Minwax® PolyShades®

Miscellaneous

- Minwax® Blend-Fil® Pencils
- Minwax® Stain Markers™
- Wood glue
- Minwax® Paste Finishing Wax
- Tack cloth
- Synthetic bristle brushes
- Clean rags
- Paint thinner, if required
- Water-filled metal container with cover

PROCEDURE

I. Carcase

1. Lay out all parts, marking each board with an ID. letter as shown in the shopping list.
2. Rough cut the pairs of boards for those members which will be made from edge-glued boards, (top, bottom, sides, shelves). Final trimming to exact dimensions is best left until after joining, as board slippage can occur during joining.
3. Align the pairs of boards so they present the most pleasing visual grain; mark the mating pieces for the biscuit locations.
4. Cut biscuit grooves with plate joiner.
5. Apply carpenter's glue to board edges and biscuits; join boards, making sure ends are aligned, and clamp together using bar clamps. Set aside for at least four hours.
6. When glue is completely dry, remove clamps and cut top, bottom, sides and shelves to their finished dimensions.

7. Align the side pieces back-edge to back-edge, inside surfaces up, and secure with a bar clamp. Next, carefully lay out for all dados and edge rabbets using a pencil and framing square.

8. To plough dados and rabbets using a router, you must clamp a straightedge a distance from the desired groove equal to the distance from the router shoe edge to router bit, so that when the router shoe rides along the straightedge, the dado will be cut exactly where wanted. Determine the distance by first making a test cut in scrap wood. After determining the exact distance that the straightedge should be clamped from the dado edge, clamp guide to the piece and plough the first dado using a 3/4" straight bit set to a depth of 1/4". Repeat technique to cut all dados and rabbets as shown in plan.

Builder's Tip: *It is essential that mating (opposite) dados be aligned or your assembled piece will be out-of-square. So, from this point on, the side boards must remain clamped together until all dados have been routed. Should the clamp in use interfere with positioning the straightedge for routing the last dado, secure a second clamp before releasing the first.*

9. Repeat Step 8 to cut the (blind) dadoes in the two shelves which will receive the 1/4" thick hardboard dividers. For these dadoes, insert a 5/16" straight bit in your router to provide extra width so dividers will "float" in their grooves. Make certain you mark dadoes to stop 1" from the front edge of shelf. If necessary, clamp a stop for the router shoe to strike against so the cutting action will stop.

Builder's Tip: *Securely clamp the shelves back-edge to back-edge, inner surfaces up, when you lay out for and rout divider dadoes.*

10. Use a piloted 3/8" rabbet cutter in the router to prepare back edges of sides, top and bottom, to receive back panel.

11. Lay out, measure and cut back rail and top cleats from scrap stock.

12. Temporarily assemble sides, bottom, shelves, back rail and cleats. Tack-nail the parts together to test fit by partially driving 1-1/4" brads. Do not use glue. Take measurements to determine the size to which the three 1/4" dividers should be cut. Cut these parts and, from the rear, slide them into the cabinet to check fit. When satisfied with fit, withdraw dividers, and with a block plane slightly round the dividers' front edges so they neatly fit rounded ends of grooves.

13. Measure and rough cut the cabinet back Insert to check fit. Trim if necessary.

14. Lay out and cut the dovetail at both ends of the front rail using a dovetail saw. With cabinet still temporarily assembled, hold the rail in position against the sides at top and mark both sides for the dovetail mating cuts. Cut out the sides using a dovetail saw and 1/2" chisel.

Builder's Tip: *Make matchmarks on one side and mating rail end to ensure that in final assembly the part will be positioned exactly as they were during the marking and shaping step.*

15. While the cabinet is still assembled, use a framing square, ruler and pencil to lay out and mark all screw and dowel plug locations in the sides and top.

16. Bore the pilot, shank and counterbore holes for all locations. If you lack the bit for drilling all three diameters in one step, start by boring the largest diameter hole for the dowel plug (3/8" dia.), then switch to a bit sized to permit the shank to move freely through the first board and, finally, insert the correct size bit to bore the pilot hole in the second board to receive the screw threads.

17. Cut bottom trim pieces to finished length and width. Shape one edge using a cove cutter in the router. Give the cove cut a light sanding with 120-grit paper if necessary.

18. To obtain tight, professional-looking miter joints in the baseboard:

a) Cut an oversized end piece (approx. 12") and hold it in place along one side at bottom, with the board extended approximately 1/2" beyond the back edge; make a pencil mark at front edge where the miter is to be cut. Cut the miter. Using 1" brads, tack-nail the first side piece of trim to the cabinet.

b) Cut a miter to mate with the first board on the end of 24" length of baseboard. Hold the latter in place with the miter joint tightly closed and mark the miter cut at the other end. Make the second miter cut and tack-nail this piece into place.

c) Repeat for third and final piece.

Builder's Tip: *The side pieces can be left overlong until after final cabinet assembly. At that time they can be trimmed flush with the back using a fine-tooth crosscut saw.*

19. With cabinet still assembled, position the top board and mark it for both length and width. Trim to exact size.

20. Cut backsplash to size.

21. Using glue and 6d finishing nails, attach backsplash to top and clamp top assembly to the cabinet's front rail so it can't move while you mark for screw locations.

22. Drill the counterbored holes for the screws that will hold cabinet together.

23. Make a careful inspection of the completed carcass. When satisfied, disassemble.

24. Sand all parts smooth starting with 100-grit paper and moving up to 120- to 150-grit paper. Remove dust between sandings.

II. Carcase - Final Assembly

1. Reassemble the cabinet using glue in all joints.

2. Lay one side piece on your workbench, dadoed surface up. Spread glue in the dadoes using either a thin wooden spatula or narrow glue brush.

Builder's Tip: *Proper gluing technique requires a thin film of glue over both (mating) surfaces. Remember, excess glue can mar the finish.*

3. Working swiftly, apply glue to mating edges of all shelves and push them into the dadoes. If there is any warp and boards need nudging in their grooves, use a mallet to gently tap each shelf into place.

4. Turn cabinet onto its back and quickly install drywall screws. Drive screws only part way until all are in place, then drive all the screws fully home. Keep the side as parallel as possible to the shelf edges so shelves are squarely seated in grooves.

5. Slide the dividers in place. Do not use glue as dividers are designed to "float."

6. Attach remaining side, back rail and cleats; glue and screw into place.

7. Make certain that all horizontal members are fully seated in their respective grooves and that the cabinet is square. Use bar clamps, if necessary. Use wood pads under clamp jaws to prevent damage to cabinet sides.

8. To ensure cabinet remains square while glue dries, temporarily tack-nail the cabinet back into place using four or five partially driven 3d nails. Note: the back will be installed permanently after drawer construction is complete.

9. Install front rail after lining up the matchmarks made earlier. Use a scant amount of glue and several 17 gauge 1 1/4" brads to secure. Carefully drive one brad through each dovetail into the side. It may be wise to bore a pilot hole for the brad to prevent splitting.

10. Next, join the top to the carcass using glue and 1 5/8" drywall screws.

11. Allow glue to rest for at least four hours, then remove clamps. Inspect the piece and slightly round over any sharp corners with a smooth file and 120-grit sandpaper.

12. Cut the required number of 3/8" long dowel plugs. Squirt glue into each hole and press plugs into place to conceal screwheads. If possible, allow plugs to rest overnight before sanding. Projecting plugs should be sanded flush with cabinet surface using 120-grit paper in the random orbit sander. Finish all carcass sanding using 150-grit paper in the pad sander always working with the grain.

13. Use carpenter's glue and 4d finishing nails to attach baseboard trim pieces. Start by installing a side piece, then the front, and then the remaining side. To ensure that miter joints stay closed:

a) Apply a thin film of glue to mating miter surfaces before pressing them together.

b) After all three pieces are permanently installed on the cabinet, drive 1 1/4" brads through the joints at 90 degrees to each other.

Builder's Tip: Set all nails slightly below the surface, but do not fill the depressions because most fillers do not accept stain, thereby leaving a white blotch in the finish. Instead, after all the finishing is done, use a matching Minwax® Blend-Fil™ Pencil to fill the depressions. Pencil colors can be mixed to match most colors.

14. Carefully measure doors and cut to size.

15. Lay out for the hinges and cut the mortises in both door edges and cabinet sides using a 1/2" chisel and hammer.

16. Hang doors.

17. Lay out doorknob locations and bore holes to suit machine screws.

18. Install metal plate for the magnetic catch on back of the left hand door. Then, hold the door shut and flush with front; working from the back, mark the location for the magnetic catch on the top's underside. To do so, simply draw a line along the inside face of the door alongside the metal plate, then make a second mark on the top's underside to indicate the plate's center line.

19. Open door; align and install the magnetic catch using two screws provided with the hardware. Magnets should be set back approximately 3/4" from front edge of shelf.

Builder's Tip: When correctly adjusted, a magnetic catch should just "kiss" the plate. If the magnet grips the plate too tightly, back out the two screws, adjust magnet position and re-drive screws. When satisfied, drive a small brad through the catch to lock it in position.

20. Cut, shape, sand and affix the small latch and install it on the left door using a 1 1/4" roundhead brass screw. The latch is used to keep the right door in the closed position.

21. Lay cabinet on its back and tap in four furniture glides to prevent rocking. Note: Nylon 7/8" dia. glides were used in this project.

III. Drawers (Build both drawers at one time)

Carefully measure the openings in your piece and, if necessary, adjust the dimensions shown in the plans to suit. The drawers you build must fit the organizer you just built. Your goal is to construct drawers that have 1/8" clearance overall, that is, 1/16" each side. Remember to mark all dimension changes in red pencil on your diagrams.

1. Cut all drawer members to exact size.

2. Lay out for and plough dados and rabbets as illustrated.

3. Dry-assemble (without glue) the drawer sides, front and back to check size and fit in cabinet.

4. Measure for, cut and slide the drawer bottoms into place, but do not attach them.

5. Insert drawers into cabinet to check that they slide freely. Make adjustments if necessary.

6. Leave drawers in cabinet flush with the front; measure and mark location for knobs. Make certain that knobs are in perfect vertical alignment. Mark, but do not bore screw holes.

7. With drawers still flush with cabinet front, determine exact size and location for drawer stops at drawer back corners. Remove drawers and measure for the four stops. Cut stops to suit; glue and tack into place.

8. When satisfied with drawer construction, disassemble them. Keep parts for both drawers in separate piles.

9. Bore holes through drawer fronts for knobs. To prevent chipping on the back side when bit breaks through, clamp a block of scrap wood tightly against the inside face of drawer front.

10. Check all surfaces for smoothness. Sand, if necessary, working up to 150-grit paper.

11. Assemble drawers using glue and 1 1/4" nails. Start by securing the sides into the front rabbets.

12. Align the back flush with the sides at top and secure it with glue and small nails.

13. Apply glue to the bottom edge of the drawer back, and slip the drawer bottom into the grooves in the sides; push it forward until it sits in the groove in the drawer front. Remove excess glue with damp cloth.

14. Set the drawers on a flat surface; allow glue to dry for a minimum of four hours.

15. Attach back to carcass.

IV. Staining and Finishing

1. Read and follow label instructions for all products.

2. Remove hardware from drawers and doors.

3. Wipe all surfaces with a tack cloth to remove all traces of dust.

4. Apply Minwax® Pre-Stain Wood Conditioner according to label instructions. Wait 15 minutes, and wipe away excess using a clean rag. Apply stain within two hours.

5. Sand again lightly with 220-grit paper and wipe clean.

6. Apply Minwax® Wood Finish™ Wood Stain to carcass following label instructions. Note: The doors and drawers can be stained or painted to match or contrast with the body according to personal preference.

7. Apply Minwax® Wood Finish™ to the top and backsplash (and doors and drawers if desired) according to label instructions. Wait 5 to 15 minutes, depending on desired tone. Wipe off excess with clean, lint-free rag.

8. Wait at least 24 hours and then apply Minwax® Fast-Drying Polyurethane to all surfaces per label instructions. This is a water-based finish, so do not overbrush or tip off. Allow to dry for at least four hours.

9. When dry, lightly sand with 220-grit paper and wipe clean with a tack cloth.

10. Apply second coat of Minwax® Fast-Drying Polyurethane. When dry, reinstall hardware on drawers and doors.

11. Allow finish to cure for approximately two weeks.

V. Clean Up

- If you have product left over, wipe the can rim so that product in the rim won't dry out and prevent the lid from forming a tight seal.
- Clean brushes used for oil-based finishes with mineral spirits; soap and water is all that is needed for brushes used for water clean-up products.

FINISHER'S TIPS

- You can slightly round or "break" sharp edges on raw wood by using 100-grit paper in the pad sander. For an even more rounded look, round edges with the router and a 1/4" rounding-over bit.
- Sand raw wood to at least the 150-grit level; use even higher grits for hardwoods such as walnut and birch.
- All stains and finishes should be allowed to dry thoroughly between coats. Sanding between coats should be done with 180-grit to 220-grit sandpaper.
- To lighten any wood tone use Minwax® Wood Finish™ Natural per label instructions. Recommendation for this project: One part Minwax® Wood Finish™ Natural to two parts Minwax® Wood Finish™ Early American.

Product Safety

DANGER! HARMFUL OR FATAL IF SWALLOWED. SKIN IRRITANT. COMBUSTIBLE. KEEP OUT OF REACH OF CHILDREN.

WARNING! Removal of old paint by sanding, scraping or other means may generate dust or fumes that contain lead. Exposure to lead dust or fumes may cause brain damage or other adverse health effects, especially in children or pregnant women. Controlling exposure to lead or other hazardous substances requires the use of proper protective equipment, such as properly fitted respirator (NIOSH approved) and proper containment and cleanup. For more information, call the National Lead Information Center at 1-800-424-LEAD (in U.S.) or contact your local health authority.

DANGER: Contains mineral spirits. Harmful or fatal if swallowed. Do not take internally. Skin irritant. Avoid contact with skin and eyes. Wear rubber gloves and safety glasses when handling. Combustible. Do not use or store near heat sparks, flame or other source of ignition. Close container after each use. Avoid inhalation and use only with adequate ventilation. If using indoors, open all windows and doors to make sure there is fresh air movement. If adequate ventilation cannot be maintained, wear respiratory protection (NIOSH / MSHA TC23C or equivalent) or leave area. Keep out of reach of children.

FIRST AID: If swallowed: Do not induce vomiting. Call physician immediately.

FOR SKIN CONTACT: Wash thoroughly with soap and water. If irritation persists, get medical attention.

FOR EYE CONTACT: IMMEDIATELY flush eyes thoroughly with water, then remove any contact lenses. Continue to flush eyes with water for at least 15 minutes. If irritation persists, get medical attention.

IF AFFECTED BY INHALATION: Immediately remove to fresh air. If symptoms persist, call physician.

VI. Safe Disposal of Rags & Waste

Please be mindful of the safe way to dispose of used rags and other waste. Remember that rags, steel wool and other waste soaked with oil finishes may spontaneously catch fire if improperly discarded. Place these items in a water-filled metal container immediately after use. Tightly seal the container and then dispose of it in accordance with local fire regulations. Be sure to keep the container out of reach of children.

MATERIALS SHOPPING LIST Nominal Dimensions**CARCASE**

Key	Part	Actual Dimensions	Pcs. Required
A	Sides	1 x 4 x 6'	clear pine (1 pc.)
B, F	Front rail, Top	1 x 6 x 4'	clear pine (1 pc.)**
C	Shelves	1 x 4 x 8'	clear pine (1 pc.)
D	Bottom	1 x 6 x 8'	clear pine (1 pc.)
E	Backsplash	1 x 4 x 2'	clear pine (1 pc.)
G	Base trim	1 x 4 x 4'	clear pine (1 pc.)
H, S, W	Dividers, Drawer bottoms (Top and Bottom)	3' x 3'	1/4" tempered hardboard (1 pc)
I	Doors	1 x 6 x 6'	clear pine (1 pc.)
J, K, X	Back rail, Cleats, Latch		cut from scrap stock
L, M	Filler, Skirt	5/4 x 2 x 4'	clear pine (1 pc.)
N	Back	2' x 2'	1/4" tempered hardboard (1 pc)

** crosscut board in half, edge join, then cut parts to width and length.

DRAWERS

Key	Part	Actual Dimensions	Pcs. Required
O	Stop blocks		cut from scrap stock
P, R	Sides, Back (top drawer)	1/2 x 4 x 4'	clear pine (1 pc.)
Q	Front (top drawer)	1 x 4 x 2'	clear pine (1 pc.)
T, V	Sides, Back (bottom drawer)	1/2 x 6 x 3	clear pine (1 pc.)
U	Front (bottom drawer)	1 x 6 x 2'	clear pine (1 pc.)

CUTTING LIST Actual Dimensions

Key	Part	Actual Dimensions	Pcs. Required
A	Sides	3/4 x 9 x 29"	2 required
B	Front rail	3/4 x 1 1/4 x 20"	1 required
C	Shelves	3/4 x 8 5/8 x 19"	3 required
D	Bottom	3/4 x 9 x 19"	1 required
E	Backsplash	3/4 x 3 x 21"	1 required
F	Top	1 x 9 1/8 x 21"	1 required
G	Baseboard Molding: Sides	3/4 x 2 1/4 x 9 3/4"	2 required
	Front	3/4 x 2 1/4 x 24 3/8"	1 required
H	Dividers	1/4 x 8 7/8 x 12 7/16"	3 required
I	Doors	3/4 x 9 1/8 x 11 7/8"	2 required
J	Back rail	3/4 x 3/4 x 18 3/8"	1 required
K	Cleats	3/4 x 2 1/2 x 7 1/2"	2 required
L	Filler (bottom)	1 1/16 x 1 1/2 x 18 3/8"	1 required
M	Skirt (bottom)	1 1/16 x 1 1/2 x 19 7/8"	1 required
N	Back	1/4 x 19 x 24"	1 required
O	Stop blocks	3/4 x 3/4 x 1 1/2"	4 required
P	Sides (top drawer)	1/2 x 3 15/16 x 7 5/8"	2 required
Q	Front (top drawer)	3/4 x 3 15/16 x 17 1/4"	1 required
R	Back (top drawer)	1/2 x 2 1/2 x 17 1/4"	1 required
S	Bottom (top drawer)	1/4 x 7 1/2 x 17 7/16"	1 required
T	Sides (bottom drawer)	1/2 x 4 15/16 x 7 5/8"	2 required
U	Front (bottom drawer)	3/4 x 4 15/16 x 18 1/4"	1 required
V	Back (bottom drawer)	1/2 x 3 7/8 x 17"	1 required
W	Bottom (bottom drawer)	1/4 x 7 1/2 x 17 7/16"	1 required
X	Latch	1/2 x 3/4 x 2 1/4"	1 required

Hardware:

- Six 1" diameter white ceramic knobs (Amerock, no. BP70634-30)
- Four 7/8" diameter nail-on glides (Shepherd Hardware, no. 9447)
- One magnetic catch (Amerock no. BP3473PT)
- Two pair of 1 x 1" brass hinges (Brainerd, no. 7100XC)

Miscellaneous:

- Professional strength wood glue
- 1 5/8" drywall screws
- 1 1/4", 1 1/2" and 2" finishing nails
- Length of 3/8" dowel

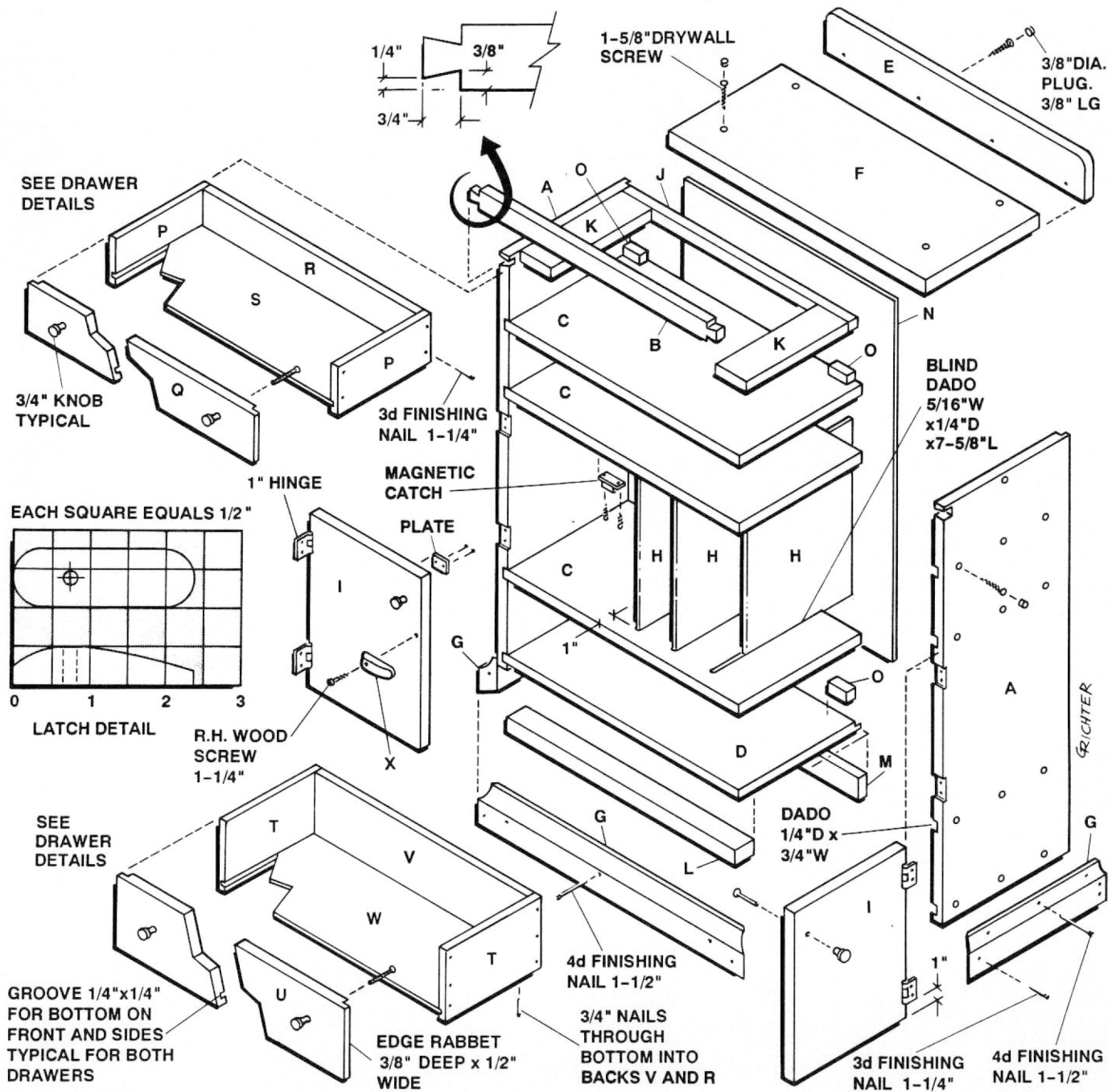

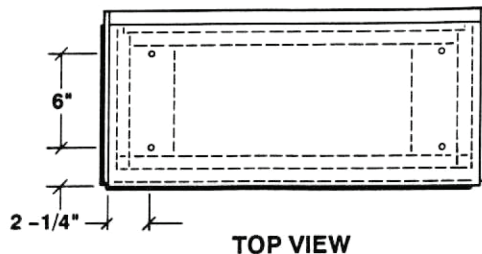

TOP VIEW

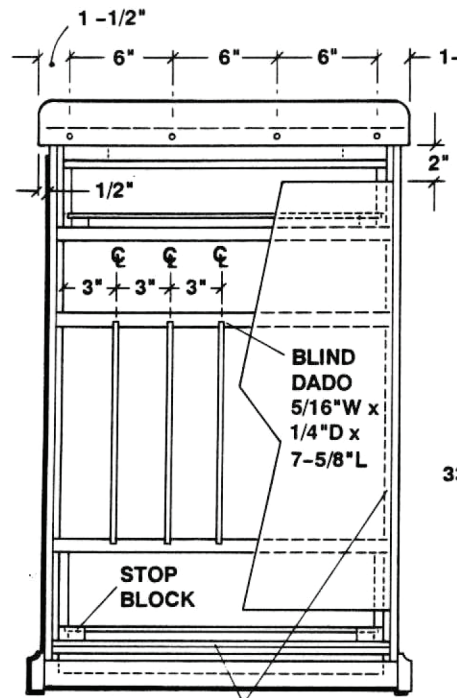

BACK VIEW

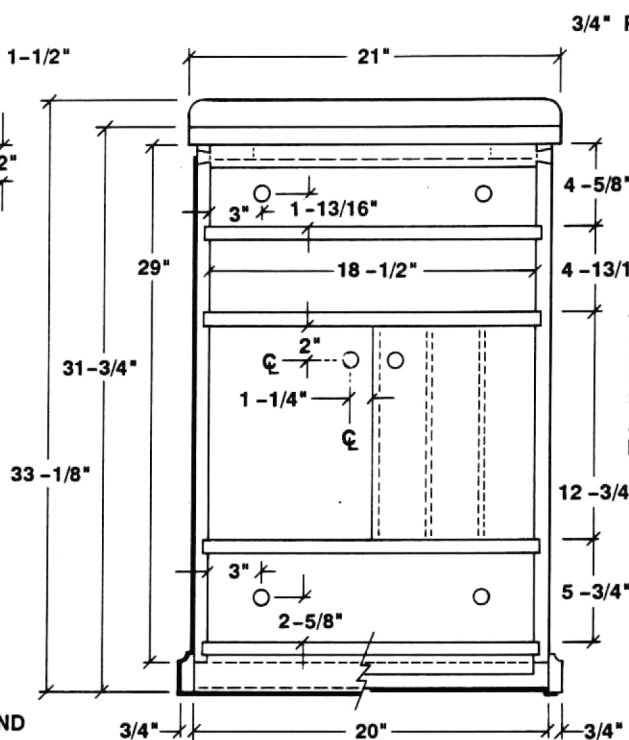

FRONT VIEW

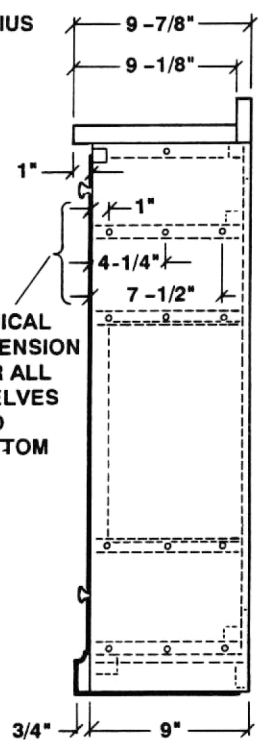

RIGHT SIDE VIEW

TYPICAL DIMENSION FOR ALL SHELVES AND BOTTOM

EDGE RABBET 3/8"x3/8" ON SIDES A AND BOTTOM D FOR BACK N

TOP VIEW

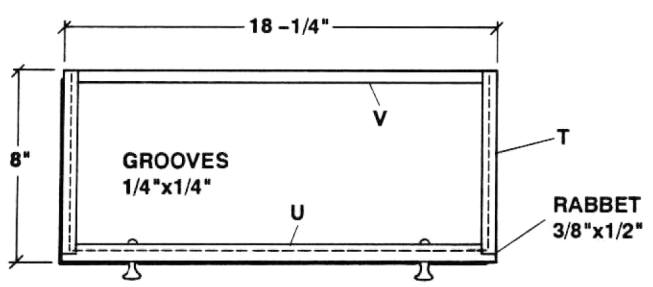

FRONT VIEW

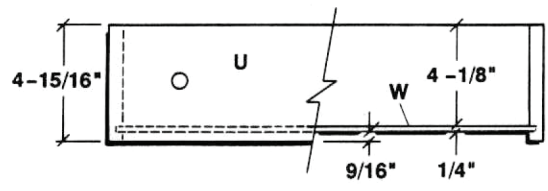

GROOVE 1/4"x1/4" FOR BOTTOM ON FRONT AND SIDES FOR BOTH DRAWERS

EDGE RABBET 3/8" DEEP x 1/2" WIDE

DRAWER DETAILS

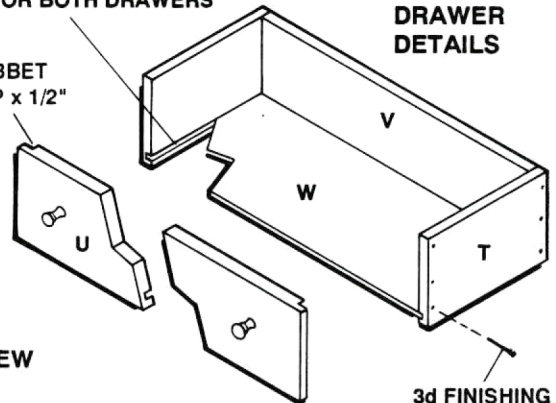

RIGHT SIDE VIEW

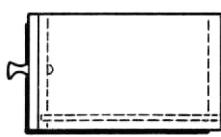

NOTE: BOTTOM DRAWER ILLUSTRATED. TOP DRAWER IS SIMILAR IN BASIC CONSTRUCTION. SEE MATERIALS LIST.